



CARDIN ELETRONICA spa
Via Raffaello, 36- 31020 San Vendemiano (TV) Italy
Tel: +39/0438.404011-401818
Fax: +39/0438.401831
email (Italy): Sales.office.it@cardin.it
email (Europe): Sales.office@cardin.it
Http: www.cardin.it

SERIAL NUMBER	SERIES	MODEL	DATE
ZVL415.01	S449	D00	02-07-2001

The S449 series conforms to the essential requirements of the directive 99/05/CE and the technical reference standards have been applied.

Frequency validity: 433.92 MHz for all countries

DIGITAL RADIO CONTROLS WITH ROLLING CODES S449



Attention! Only for EU customers - WEEE marking.

This symbol indicates that once the products life-span has expired it must be disposed of separately from other rubbish. The user is therefore obliged to either take the product to a suitable differential collection site for electronic and electrical goods or to send it back to the manufacturer if the intention is to replace it with a new equivalent version of the same product.

Suitable differential collection, environmental friendly treatment and disposal contributes to avoiding negative effects on the ambient and consequently health as well as favouring the recycling of materials. Illicitly disposing of this product by the owner is punishable by law and will be dealt with according to the laws and standards of the individual member nation.

Description

The S449 Radio control system in "FM" consists of one or more transmitters and one or more receivers which can be combined to meet the specific needs of the system. As the system use dynamic codes each code is managed individually by the receiver.

Important: The transmitted code changes for each command (rolling code). If disturbance interrupts the transmission, the receiver will wait for a different code, the relay can then only be activated by first releasing and then pressing the transmitter channel button again.

Use

The S449 radio control allows the remote activation of electrical and electronic appliances with its best use in the following areas: automatic opening systems, alarm systems and multiple access systems (apartment blocks etc.) and in all systems which require remote control activation (without wires) using secret codes.

The receiver has been designed for multiple access with UP to 1000 each of which may be memorised or cancelled individually. Each code is stored in a memory location chosen on the display and the location can activate UP to 4 functions. 1 transmitter = 4 functions max. = 1 location; 1000 users = 4000 functions max.

Transmitter versions

TRQ449100	Miniaturized transmitters	1 button
TRQ449200	Miniaturized transmitters	2 buttons
TRQ449300	Miniaturized transmitters	3 buttons
TRQ449400	Miniaturized transmitters	4 buttons
TRQ44940M	Wall mounted transmitters	4 buttons

Receiver versions

RCQ449D00	Outdoor receiver with display (1000)	4 channels
-----------	--------------------------------------	------------

Memory module

This is extractable, furnished with a non volatile EEPROM 24C64 type memory and contains the transmitter codes. The programmed codes are maintained in this module even in the absence of power without a time limit.

Antenna

To obtain the best results from the radio control device the installation of the antenna is fundamental as once connected to the receiver it represents the reception point for the transmitter. A tuned antenna using a coaxial cable RG58 (impedance 50Ω) with a maximum length of 15 m must be installed. The antenna should be positioned out of doors in the highest possible point, visible and away from metal structures. The receiver should be positioned away from computer systems, alarm systems and other possible sources of disturbance.

Transmitters

The transmitter is pre-coded and is fitted with an integrated circuit which is programmed in the factory with a unique identification number. All the code parameters are contained in this integrated circuit (external memory modules are not required) thus making code management more reliable and the system more secure.

The transmitter has an automatic shut down mechanism which cuts in after 25 seconds of continuous use (this limits battery consumption). This time can vary from transmitter to transmitter.

Receivers

Warning! The receivers must only be powered by a safety power pack. The use of non safety power packs could provoke damage to the system.

Outdoor receiver with display (fig. 4)

The outdoor receiver card (printed circuit CS1127a) is fitted with an 14-way terminal board and has the following electrical connections:

12V ac/dc between binding posts 1-2 - **24V ac/dc** between binding posts 1-3.

The outdoor receiver is fitted with "fast-fitting" brackets. Fix the bracket to the wall using two rawlplugs (check that it is in square). After connecting the wiring slide the case onto the bracket therefore fixing it to the wall. If any repair work is necessary the case can be easily extracted by pushing upwards the action of which will separate it from the bracket.

Interchangeable channel modules

In the receivers the channel functions are printed on the circuit board. Only type MCC4491R0 relays can be used.

Attention! If the receiver is powered by "24V" you may simultaneously activate two of the four available relays plus one impulsive relay. It follows therefore that you must pay attention to the type of function each relay has. If the receiver is powered by "12V" there is no limitation.

Receiver functions

The following functions are managed by the PGM449 for more details consult the manual supplied with the product.

Blocking buttons: The receiver programming buttons can be disabled to prevent unauthorised use.

PIN code security: This function uses a PIN code to prevent unauthorised use of the receiver.

TRS substitution: This function allows you to replace a transmitter without opening the container

Attention! Before memorising the transmitters for the first time remember to cancel the entire memory content.

Setting up the relays (fig. 5)

The display type receiver S449 uses an "Impulsive" type relay that can be programmed as an "On-Off" or "Timer" relay by the receiver. When setting UP relays the UP/DOWN/MEMO and DEL buttons have special functions.

When the receiver switches on the firmware version will be shown. This is represented by an "r" followed by two digits which will disappear after one second. If the palm has enabled the PIN code security function (in the receiver memory) the flashing indication "PIN" will appear and disappear after 10 seconds. The location number "001" (fig. 5a) will now automatically appear indicating that the receiver is ready to accept a command. The indications on the display are maintained for 4 seconds after the last command was received (either via radio or using the buttons on the receiver) after which the stand-by mode will appear; only the right hand decimal point will be lit (fig. 5b).

To program the relays proceed as follows:

- 1) Simultaneously press the "UP" and "DOWN" buttons (fig. 5c) and the central line on the display will light UP. If you keep the buttons pressed DOWN for 10 seconds the symbol (fig. 5d) will appear, indicating that you have entered the relay programming mode.
- 2) Using the "UP" button (fig. 5e) choose the function you wish to modify. Each time you press the button the display will show the next function in the sequence CH-A,B,C,D (fig. 5e, f, g, h).
- 3) Using the "DOWN" button (fig. 5i) choose the relay mode to associate with each channel. Each time you press the button the display will show the setting in the following sequence "Impulsive", "Timer", "ON/OFF" (fig. 5j, k, l).
- 4) To set the timer in the "Timer relay method" (fig. 5k) press the MEMO/DEL (fig. 5m), set the desired time using the "UP" and "DOWN" buttons (e.g. 120 s fig. 5n), max. 255 s then press the MEMO/DEL button again (fig. 5q). The chosen time will be set for the desired relay.

- 5) To confirm the new channel settings, press the "UP" button until the symbol (fig. 5p) appears on the display and then wait for 20 seconds after which period the receiver will store the new settings.
- 6) To exit the relay programming mode without saving the changes wait for twenty seconds with anything on the display other than the indication in (fig. 5p). The receiver will ignore any changes which have been made.

Memorising a channel (fig. 6)

- It is possible to add new transmitters or program new functions into an already memorised transmitter at any time with the following exceptions:
 - If the transmitter you wish to memorise is already present in a different memory location or the function is already present, the receiver will automatically exit the programming mode and indicate the location in which the transmitter code is memorised.
 - If the receiver doesn't appear to respond to the transmitter button, wait for a few seconds (if you have a high number of codes memorised the receiver). To avoid accidentally memorising transmitters the receiver will ask you to confirm the transmitted code by pressing the channel a second time.
 - All operations are carried out manually. If you release the "MEMO/DEL" before the procedure has terminated nothing will be memorised.
 - The dots on the display indicate the location status: no lit dots indicates an empty location; one lit dot indicates an occupied location (1 to 3 channels); two lit dots indicates an entirely occupied location (4 channels)
- 1) Make sure the jumper "J1" (fig 4-6a) is inserted.
 - 2) Choose the desired location using the "UP" and "DOWN" buttons (fig 6a) which increase and decrease the displayed number (keep the button pressed DOWN to scroll faster).
 - 3) Press the "MEMO/DEL" button and make sure that (fig 6c) appears.
 - 4) Press (for about 1 second) the button on the transmitter that you wish to memorise (fig 6d) until either the symbol (fig 6e) or an already memorised location appears.
 - 5) Press the channel button a second time to confirm it and a letter indicating the inserted function will appear on the display e.g. (a,b,c or d, as shown in fig 6f).
 - 6) The procedure is now finished. Release the button and the memory location will be shown with the status points updated e.g. (fig 6g-h).
 - 7) To memorise another channel button repeat from point 3; for a new transmitter repeat from point 2.

Cancelling a channel/user or entire user memory (fig. 7)

- You do not need to have the transmitter to be able to cancel. This allows you to cancel a transmitter which has been lost without having to cancel all codes and consequently having to re-insert all the codes (obviously you must already know the memory location for this to work).

Caution! Keeping the MEMO/DEL button pressed for more than 20 seconds will wipe the entire memory (the codes cannot be recovered). The indication "CLA" appears on the display (fig 7k) when the entire user memory has been cleared.

- 1) Make sure the jumper "J1" (fig 4-7a) is not inserted.
- 2) Choose the desired location using the "UP" and "DOWN" buttons (fig 7b) which increase and decrease the displayed number (keep the button pressed DOWN to scroll faster).
- 3) Press the "MEMO/DEL" button and make sure that the indication in (fig 7c) appears.
- 4) The letters indicating the function will appear on the display in sequence (fig 7d-f) separated by the "Nil" indication (fig 7e-g). After the four function letters have appeared the symbol "ALL" (fig 7h) will appear on the display (indicating that the entire location has been cancelled) after which the sequence will start again. Only the memorised functions will be shown so if the location is empty the "Nil" indication (fig 7i) will be shown followed by the symbol "ALL" (fig 7h). Keep the button pressed to scroll through the indications on the display and release the button when you reach the desired location. Releasing the button with the "Nil" symbol (fig 7j) on the display will abort the cancellation procedure leaving the location unaltered.
- 5) If a cancellation operation has been selected the indication (fig 7j) will appear to confirm that the command has been carried out after which the memory location will once again be shown.
- 6) Repeat points 1 to 4 for all ulterior cancellation procedures.

ERROR CONDITIONS

- The receiver is fitted with error diagnostics. The error situations are indicated on the display by the symbol "Er" flashing followed by an error identification number. The error numbers are as follows:



WRONG MEMORY PARAMETERS

- The parameters in the memory module are wrong and the receiver will attempt to manage any eventual data that can read in order to allow the receiver to function. This indication can also be caused by a new memory module (not yet set up to operate) or by a defective or corrupt memory module. If the error indication persists do not use the receiver and contact the after sales service.



MEMORY MODULE MISSING OR DAMAGED

- The receiver is unable to read the code memory and to preserve the data contained in the module it will block the operation and signal this error code. This error will also appear if the receiver is switched on without a memory module inserted or if you remove the module while the receiver is functioning (THIS MUST NEVER BE DONE!).



CORRUPT PIN CODE

- The PIN code security data is corrupt. The receiver will be blocked because this could be the result of an attempt to breach the installation security. Consult the PGM449 instructions for how to manage this error.

TECHNICAL SPECIFICATIONS

Receiver

- reception frequency	433.92 MHz
- local oscillation tolerance	±30 PPM from -20 to +75°C
- sensitivity (finely tuned signal)	-110 dBm 0,7 µV
- selectivity	±30 kHz
- modulation	FSK
- modulation with ΔF	≤ 20 kHz
- antenna impedance in input	50Ω
- receiver power supply	12/24V ac/dc
- maximum power consumption (depending on the number of relays)	22/145 mA
- maximum commutable power at the relay with ac/dc resistive load:	60VA/24W
- maximum voltage applied at the relay contacts	30Vac/dc
- relay activation delay time	0,1 ÷ 1,3 s
- maximum relay setting time	255 s
- operating temperature range	-20° ... +75°C

Transmitters

- carrier frequency	433.92 MHz
- carrier frequency tolerance	±30 kHz
- apparent radiated power	-10 ... -7dBm (100-200µW)
- modulation	FM/FSK
- modulated with ΔF	≤ 20 kHz
- power supply (lithium battery)	2 x CR2032
- power consumption	35 mA
- operating temperature range	-10 ... +55°C
- relative humidity	< 95%
- type of encoding	rolling code (2 ²⁶ combinations)
- number of channels	4
- automatic shut down	after at least 25 seconds

DIMENSIONI D'INGOMBRO - OVERALL DIMENSIONS
DIMENSIONS D'ENCOMBREMENT - AUSSENABMESSUNGEN
DIMENSIONES DEL ESPACIO OCUPADO

1

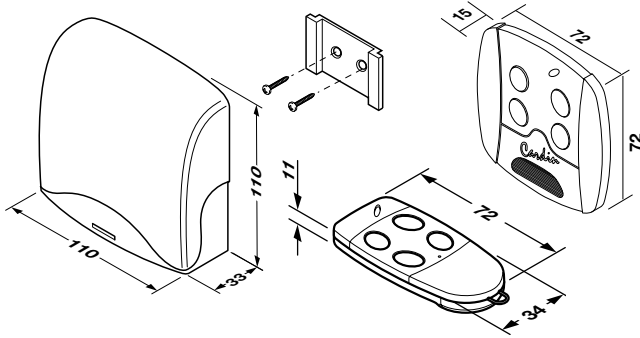

CAMBIO BATTERIA - CHANGING THE BATTERY
REPLACEMENT DE LA PILE - BATTERIEWECHSEL
SUSTITUCIÓN DE LA PILA

2

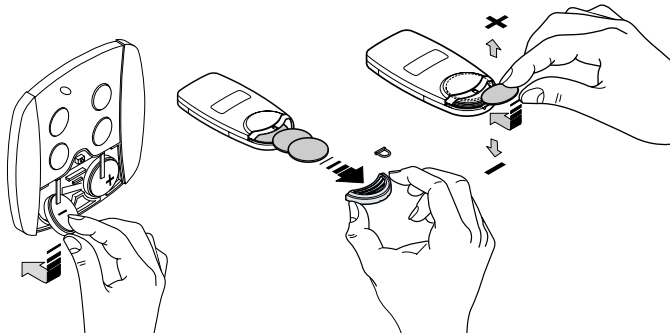

SELEZIONE DEI CANALI - CHANNEL SELECTION
SÉLECTION DES CANAUX - WAHL DER KANÄLE
SELECCIÓN DE LOS CANALES

3

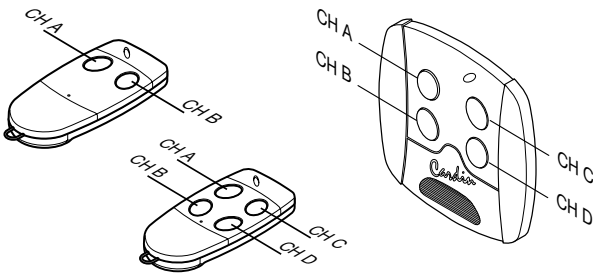

RICEVITORE IN CASSETTA CON DISPLAY
OUTDOOR RECEIVER WITH DISPLAY
RÉCEPTEUR AVEC AFFICHEURS SOUS BOÎTIER
AUSSENEMPFÄNGER MIT DISPLAY
RECEPTOR EN CAJA CON DISPLAY

4

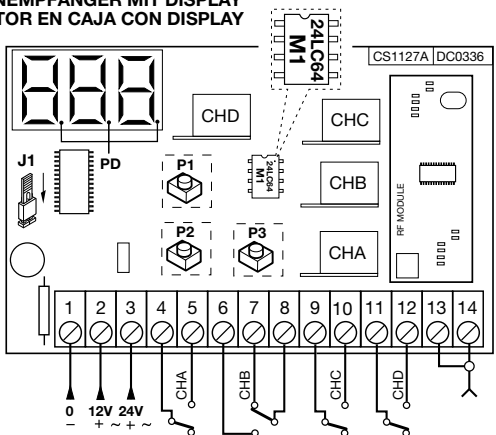

Legenda
J1: Ponticello di selezione MEMO/DEL
 - Inserito: memorizzazione canali su P3
 - Disinserito: cancellazione canali su P3
M1: Modulo di memoria
P1: Avanzamento locazioni
P2: Decremento locazioni
P3: Cancellazione/memorizzazione codici
PD: Punti decimali

Nomenclature
J1: Cavalier de sélection MEMO/DEL
 - Connecté: mémorisation des canaux sur P3
 - Déconnecté: effacement des canaux sur P3
M1: Module de mémoire
P1: Défilement en avant des plages de mémoire
P2: Défilement en arrière des plages de mémoire
P3: Effacement/mémorisation des codes
PD: Points décimaux

Legend
J1: MEMO/DEL selection jumper
 - Inserted: memorise channels using P3
 - Not inserted: cancel channels using P3
M1: Memory module
P1: Scroll memory locations UP
P2: Scroll memory locations DOWN
P3: Cancel/memorise codes
PD: Decimal points

Zeichenerklärung
J1 Überbrückung zur Wahl MEMO/DEL eingesetzt: Kanalspeicherung auf P3
 - herausgenommen: Kanallöschung auf P3
M1: Speichermodul
P1: Vorlauf Speicherplätze
P2: Rücklauf Speicherplätze
P3: Löschung/Speicherung der Codes
PD: Dezimalpunkte

Legenda
J1: Puente de selección MEMO/DEL
 - conectado: memorización canales en P3
 - desconectado: borrado canales en P3
M1: Módulo de memoria
P1: Avance posiciones
P2: Decremento posiciones
P3: borrado/memorización códigos
PD: puntos decimales

IMPOSTAZIONI STRIP DI CANALE - SETTING THE CHANNEL RELAY MODE
PROGRAMMATION DES FICHES DE CANAL - EINSTELLUNG KANAL-STRIP
PROGRAMACIÓN MÓDULO DE CANAL

5

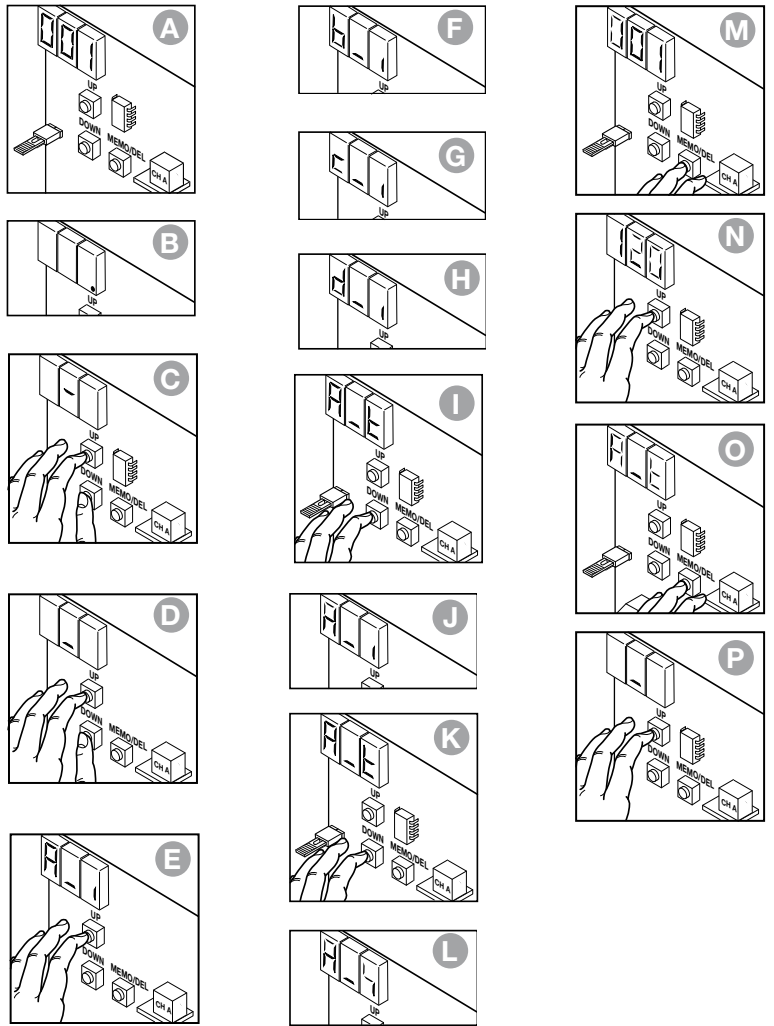

MEMORIZZAZIONE DI UN CANALE
MEMORISING A CHANNEL
MÉMORISATION D'UN CANAL
SPEICHERUNG EINES KANALS
MEMORIZACIÓN DE UN CANAL

6

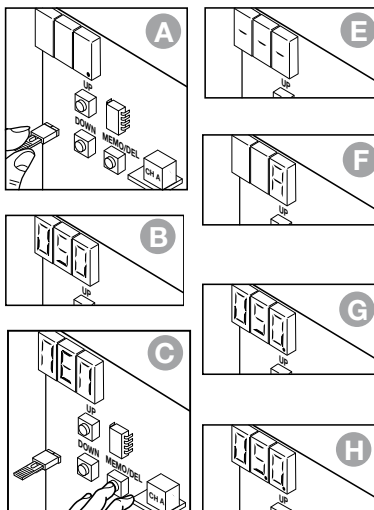

CANCELLAZIONE CODICI
CANCELLING CODES
EFFACEMENT DES CODES
CODE-LÖSCHUNG
BORRADO DE TODO LOS CÓDIGOS

7

